

Performance Evaluation of Nonlinear PI Controller on the Laboratory Type Spherical Tank Process

T. Bhuvanendhiran¹ and S. Abraham Lincon²

¹Research Scholar, ²Professor, ^{1&2}Department of Electronics and Instrumentation Engineering,
Annamalai University, Annamalai Nagar, Tamil Nadu, India
E-Mail id: tbhuvanendhiran@yahoo.co.in

Abstract - In this paper, the implementation of Nonlinear PI controller based on error square type is designed and adopted to control of level in a spherical tank process. By use of black box model the system is found as a First order plus Dead Time model (FOPDT). Then the controller tuning strategies has been adopted namely Direct synthesis (IMC), Skogestad (IMC PI), and Nonlinear PI (error square type) tuning. Among all the three controllers tuning the error square type based Nonlinear PI tuning method shows better control performance than the other two controller tuning in terms of performance indices like Integral Square Error (ISE), Integral Absolute Error (IAE) and Time domain specifications.

Keywords: Nonlinear PI, Direct Synthesis IMC PI, Nonlinear Process, SIMC, System Identification

I. INTRODUCTION

In Different Industrial Automation Control Systems, the PID control schemes are widely used for a long time [1]. The PID controller is the most common form feedback and consist of in many different forms but limited to more complex Nonlinear system due to lack of efficiency. Due to this reason, Nonlinear PI controller is implemented in much Industrial process, where the parameters are depending on quantity of system error. Generally, a nonlinear combination can provide additional degrees of freedom to obtain better control performance [2-5]. The conventional linear PID controller is modified by use of nonlinear characteristics in recent years [6]. However, an advanced control strategies are adopting in different nonlinear processes, still much research has been going on in tuning the PID controller to achieve better control performance for many processes like large dead time, integrating process and first order process with Dead time (FOPDT) model. Wang *et al.*, [7] have discussed about PID controller design using LMI approach. Visioli [8] designed a PID plus feed forward controller for an inverse model system. Astrom and Hagglund [9] have proposed the new tuning rule to give a robust performance for a process with essentially a step response. Toscano [10] have proposed simple PI/PID controller based on numerical optimization approach. Nithya *et al.*, [11] have discussed about the control aspects of spherical tank using Internal Model based Controller (IMC) PI tuning setting in real time. They discussed that the IMC gives better performance in tracking the set point and load changes with faster settling time and exhibit less over shoot with no oscillation.

In this Research work, a Nonlinear PI control algorithm (error square type tuning) was implemented to a spherical tank process to increase the better control quality at different operating regions. The performance indices have been compared with two tuning methods i.e., direct synthesis IMC PI and Skogestad IMC PI tuning.

II. SYSTEM DESCRIPTION

A. Spherical Tank Process

A sphere is a very strong structure. The even distribution of stresses on the sphere's surfaces, both internally and externally, generally means that there are no weak points. That's why a drop of water forms a spherical shape when under free fall, in short; it achieves a shape where all the resultant stresses neutralize when no external force is acting on it. Moreover, they have a smaller surface area per unit volume than any other shape of vessel. This means, that the quantity of heat transferred from warmer surroundings to the liquid in the sphere, will be less than that for cylindrical or rectangular storage vessels. It is used in many applications in Petroleum Industries, Paper Industries, Water treatment plants and Chemical Industries etc., [12].

B. Mathematical Modeling of Spherical Tank Process

Fig.1 shows the schematic diagram of spherical tank level system, in which the control input fin is being the in- flow rate (m³/s) and the output x is the fluid level (m) in the spherical tank.

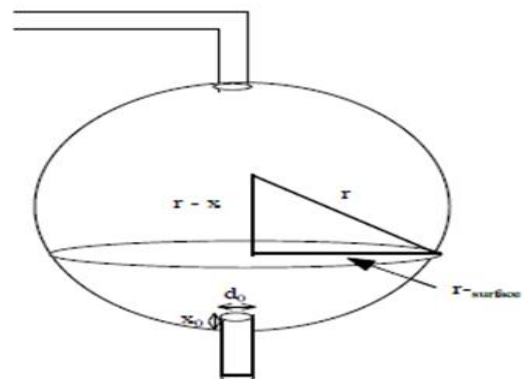

Fig. 1 Schematic diagram of Spherical Tank Level Process

Let, r , d_0 and x_0 be the radius of spherical tank, thickness (diameter) of pipe and initial level. Assume 'r surface' is radius on the surface of the fluid which varies with respect to the level of fluid in the tank. The dynamic model of the spherical tank is given as [13].

$$\frac{dx}{dt} = \frac{f_{in} - f_{out}}{A(x)} \quad (1)$$

Where $A(x)$ is the area of the cross section of tank (i.e.) $2rx - x^2$

a is the cross sectional area of the pipe (i.e.)

$$a = \frac{d_0^2}{4}$$

Rewrite the equation (1) at time, t

$$\frac{dx}{dt} = \frac{f_{in} - f_{out}}{2rx - x^2} \quad (2)$$

Combine equation (1) and (2)

$$\frac{dx}{dt} = \frac{f_{in} - f_{out}}{2r} \frac{d_0^2}{4} \sqrt{2g} \quad (3)$$

By applying $\lim_{d \rightarrow 0}$ in above equation then, $\frac{dx}{dt}$

Therefore

$$\frac{dx}{dt} = \frac{f_{in} - f_{out}}{2r} \frac{d_0^2}{4} \sqrt{2g} \quad (4)$$

Equation (4) Represent the dynamic model of the spherical tank level process.

C. Transfer Function Model of the Spherical Tank Process

The system identification of this non-linear spherical tank system is done by using block box Modelling. For fixed inflow rate and outflow rate of the spherical tank, the tank is allowed to fill with water from 0 to 50cm. At each sample time the data from differential pressure transmitter i.e. between 4 to 20mA is being collected and fed to the system through the serial port RS – 232 using VMAT-01 interfacing module. Thereby the data is scaled up in terms of level (in percentage). The total height of the tank is 0-50cm. It is converted in terms of 0-100%.

TABLE I TRANSFER FUNCTION PARAMETERS AT DIFFERENT OPERATING POINTS

Models	Operating point (%)			
Model 1	20-39	5.083	620.24	29
Model 2	40-59	5.469	1015.8	30
Model 3	60-75	4.202	1291.2	30

Using the open loop method for a given input step change, the output response of the system is recorded with help of PC. In order to find the open loop transfer function model of the spherical tank system at three different operating regions, the level ranges from 20% to 39 %, 40% to 59%

and 60% to 75% lower, middle and upper level of the tank respectively. The transfer function parameters for above mentioned levels are listed in Table I [15].

III. CONTROLLER DESIGN OF NONLINEAR PI

Conventional PID controller structure is shown in equation (5)

$$m(t) = k_c e + \frac{1}{I} \int e dt + D \frac{de}{dt} \quad (5)$$

Nonlinear PI control structure [14] is shown in equation (6)

$$m(t) = \tilde{k}_c (1 + |e|) e + \frac{1}{I} \int e dt \quad (6)$$

After deriving the transfer function Model for spherical tank system, the controller parameters are obtained using Nonlinear PI control structures as shown in Table II.

TABLE II NONLINEAR PI CONTROL STRUCTURE PARAMETER

S. No.	Controller parameters
1	$\tilde{k}_c = 0.02586 + 0.0982 (/)^{1.049}$
2	$I = 0.997 + 0.08 (/)^{2.351}$
3	$y_{sp} = 4.259 + 0.5362 (/)^{0.667}$

The transfer function model for second operating region of spherical tank system is considered for controller design and the model is given in equation (7).

$$Gp(s) = \frac{5.469}{1015.8 s + 1} e^{-30s} \quad (7)$$

First order system with time delay transfer function parameters are taken from the following paper [15], the controller parameters are obtained for the process transfer function (7) using Nonlinear PI control structure and is given in Table III, the Nonlinear PI controller structure is depicted in Fig. 2.

TABLE III NONLINEAR PI CONTROLLER PARAMETERS

S. No.	Controller parameters	Values
1	\tilde{k}_c	0.72
2	I	1012.7
3		0.04

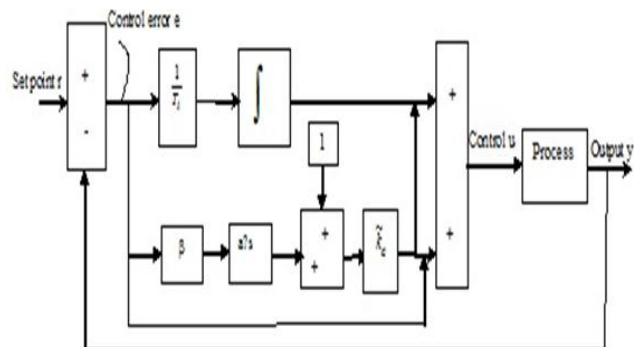

Fig. 2 Nonlinear PI Controller Structure

IV. RESULTS AND DISCUSSION

The Nonlinear PI (error square type) controller is designed and incorporated to control spherical tank liquid level process at different operating regions. Nonlinearity parameter (β) varies based on set point change thus using Nonlinear PI control structure the liquid level in a spherical tank process to be controlled at any operating points. The Servo and Servo-Regulatory responses are shown in Fig. 3 to 6 and Fig. 7 to 10 respectively.

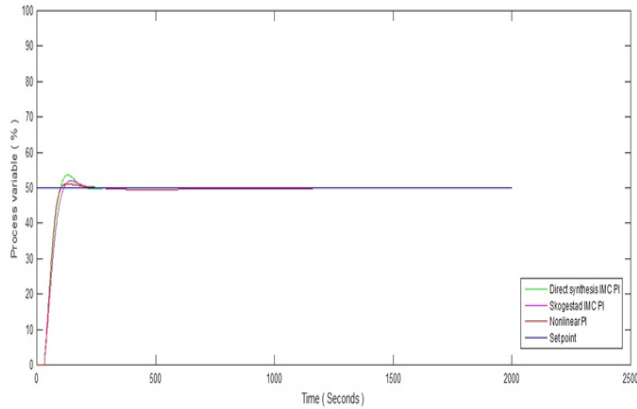

Fig. 3 Servo response of spherical tank at 50% operating point

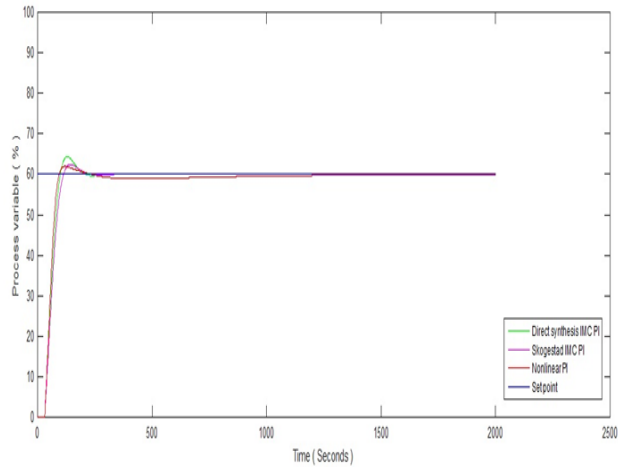

Fig. 4 Servo response of spherical tank at 60% operating point

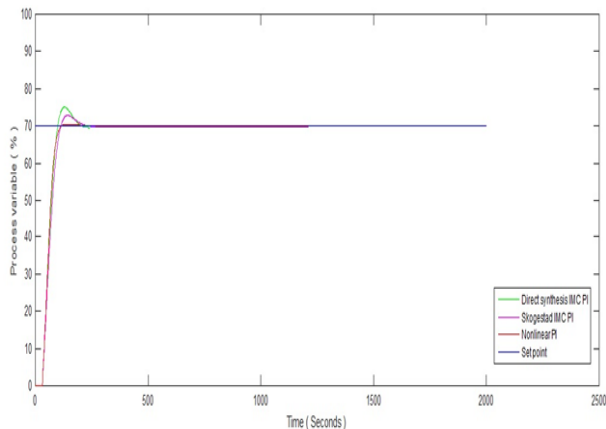

Fig. 5 Servo Response of Spherical tank at 70% operating point

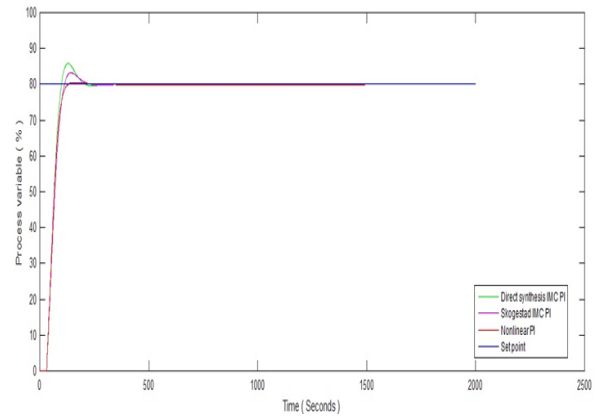

Fig. 6 Servo Response of Spherical tank at 80% operating point

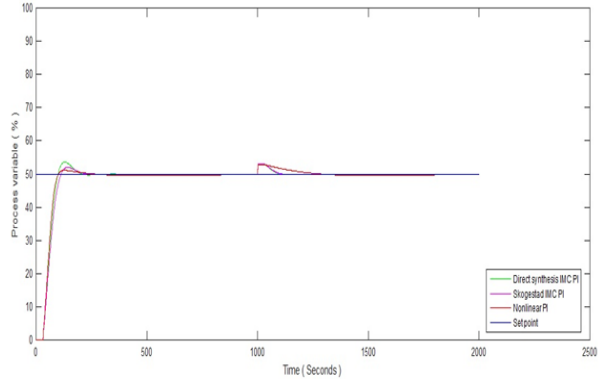

Fig. 7 Servo Regulatory Response of Spherical tank at 50% operating point

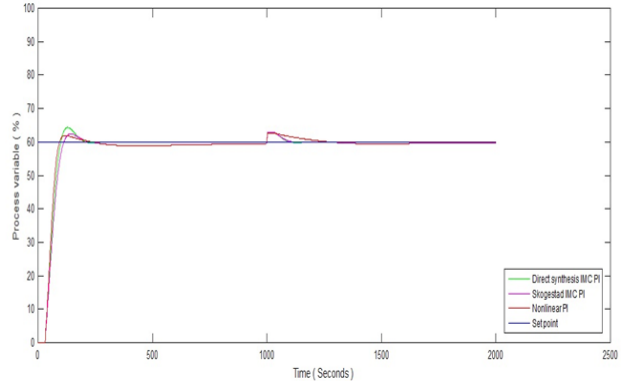

Fig. 8 Servo Regulatory Response of Spherical tank at 60% operating point

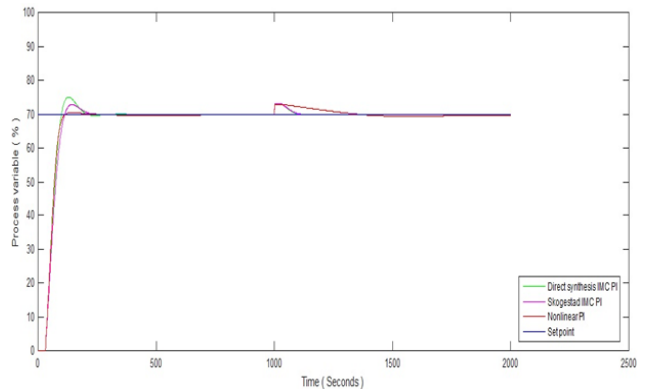

Fig. 9 Servo Regulatory Response of Spherical tank at 70% operating point

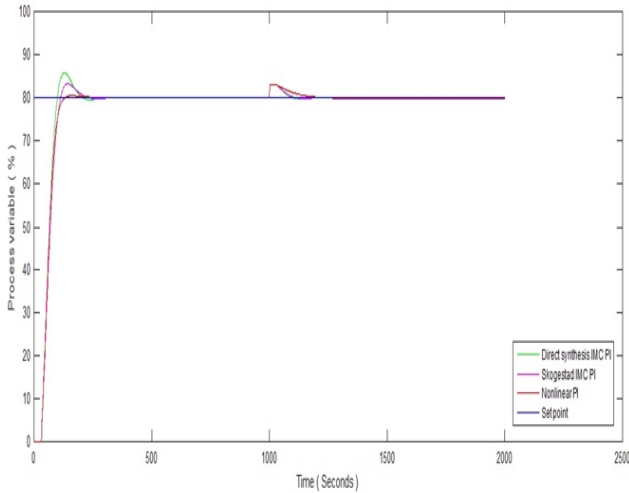

Fig. 10 Servo Regulatory Response of Spherical tank at 80% operating point

From the responses, the Nonlinear PI controller tracks the set point faster, less Over shoot and settles in faster time when compare to other two controllers. The performance indices for both servo and regulatory, time domain specifications for all the three controllers are computed and tabulated in table IV, V and VI.

From these values it is observed that Nonlinear PI control algorithm provides satisfactory performance in servo and regulatory cases than the other two control strategies.

TABLE IV PERFORMANCE INDICES COMPARISON FOR SERVO RESPONSE

Operating Regions %	Methods	Nonlinear PI	Skogestad IMC PI	Direct Synthesis IMC PI
50	ISE	1.17e ⁺⁰⁵	1.26e ⁺⁰⁵	1.22e ⁺⁰⁵
	IAE	3112	3254	3179
60	ISE	1.67e ⁺⁰⁵	1.82e ⁺⁰⁵	1.75e ⁺⁰⁵
	IAE	3701	3905	3814
70	ISE	2.34e ⁺⁰⁵	2.47e ⁺⁰⁵	2.39e ⁺⁰⁵
	IAE	4329	4556	4450
80	ISE	3.02e ⁺⁰⁵	3.23e ⁺⁰⁵	3.12e ⁺⁰⁵
	IAE	4967	5207	5086

TABLE V PERFORMANCE INDICES COMPARISON FOR REGULATORY RESPONSE

Operating Regions %	Methods	Nonlinear PI	Skogestad IMC PI	Direct Synthesis IMC PI
50	ISE	1.18e ⁺⁰⁵	1.26e ⁺⁰⁵	1.22e ⁺⁰⁵
	IAE	3369	3744	3449
60	ISE	1.68e ⁺⁰⁵	1.82e ⁺⁰⁵	1.76e ⁺⁰⁵
	IAE	4005	4677	4110
70	ISE	2.35e ⁺⁰⁵	2.48e ⁺⁰⁵	2.39e ⁺⁰⁵
	IAE	4461	5107	4751
80	ISE	3.13e ⁺⁰⁵	3.24e ⁺⁰⁵	3.15e ⁺⁰⁵
	IAE	5277	5331	5401

TABLE VI COMPARISON OF TIME DOMAIN SPECIFICATION

Level in %	Specification	Nonlinear PI	Skogestad IMC PI	Direct Synthesis IMC PI
50	Rise Time(sec)	45.91	57.16	49.83
	Settling Time(sec)	148.66	182.75	179.82
	% Overshoot	2.29	4.05	7.24
60	Rise Time(sec)	43.12	57.16	49.83
	Settling Time(sec)	165.32	182.75	179.82
	% Overshoot	3.34	4.05	7.24
70	Rise Time(sec)	48.90	57.16	49.83
	Settling Time(sec)	102.29	182.75	179.82
	% Overshoot	0.65	4.05	7.24
80	Rise Time(sec)	55.27	57.16	49.83
	Settling Time(sec)	113.26	182.75	179.82
	% Overshoot	0.65	4.05	7.24

V. CONCLUSION

In this Research work, Nonlinear PI Control algorithms were implemented to a Spherical Tank process. Simulations studies are carried out by consideration of Nonlinear PI (Error Square Type), Direct Synthesis (IMC PI) and Skogestad (IMC PI) Tuning in a closed loop system. From the results, the Nonlinear PI control algorithm offers a superior control performance than the other two controllers

moreover it has a simple control structure, capable to control highly nonlinear process.

REFERENCES

[1] K.J. Astrom, and T. Hagglund, "Advanced PID Control", *ISA-The Instrumentation Systems and Automation Society*, 2006.
 [2] B. Armstrong, D. Neevel, and T. Kusik, "New Results in NPID control: tracking, Integral Control, friction compensation and

- experimental results”, *IEEE Trans. Control Syst. Technol.*, Vol. 9, No. 2, pp. 399-406, 2001.
- [3] B. Armstrong, and B. A. Wade, “Nonlinear PID control with partial state knowledge: damping without derivatives”, *Int.J. Robotics Research*, Vol. 19, No.8, pp. 715-731, 2000.
- [4] W. H. Chen, D. J. Balance, P.J. Gawthrop, J. J. Gribble, and J.O.Reilly, “Nonlinear PID predicitive controller”, *IEE Proc. Control Theory Appl.*, Vol. 146, No.6, pp. 603-611, 1999.
- [5] J.Q. Han, “Nonlinear PID controller”, *Acta Autoatica Sinica*, Vol. 20, No. 4, pp. 487-490, 1994.
- [6] W. Wang, J.T. Zhang, and T.Y. Chai, “A survey of advanced PID parameter tuning methods”, *Acta Automatica Sinica*, Vol. 26, No. 3, pp. 347-355, 2000.
- [7] M. Ge, M. S. Chiu, and Q. G. Wang, “Robust PID controller design via LMI approach”, *J. Process Contr.*, Vol. 1, No. 12, pp. 3-13, 2002.
- [8] A. Visioli, “A new design plus for a feedforward controller”, *J. Process. Contr.*, Vol. 14, pp. 457-463, 2004.
- [9] K. Astrom and T. Hagglund, “Revisiting the Ziegler-Nicholus step Response method for PID control”, *J. Process Control*. Vol.14, pp. 635-650, 2004.
- [10] R.Toscano, “A simple PI/PID controller design method via numerical optimization approach”, *J. Process Control.*, Vol. 15, pp. 81-88, 2005.
- [11] S. Nithya, N.Sivakumaran, T. Balasubramanian and N. Anantharaman, “ IMC Based Controller design for a spherical tank process in real time”, *National conference in Advanced Techniques in Instrumentation Control and Communication Engineering*, 2008, pp. 173-178.
- [12] Ben Joe Raj, and P. Subha Hency Jose, “Fuzzy Logic Based PID Controller for a Non Linear Spherical Tank System”, *IJERT*, Vol. 3, No.2, pp. 1867-1870, 2014.
- [13] S. Ramesh, and S. Abraham Lincon, “Fuzzy Model Based Learning Control for Spherical Tank Process”, *Int. J. Engineering Research and Applications*, Vol. 3, No. 6, pp. 619-623, 2013.
- [14] T. Bhuvanendhiran, S. Abraham Lincon, I. Thirunavukkarrasu and Sarath Yadav, “Nonlinear Control Design for a Nonlinear Process-an Experimental Approach”, *J. Advanced Research in Dynamical and Control Systems*, Vol. 10, No.7, pp. 1557-1562, 2018.
- [15] A. Ganesh Ram, and S. Abraham Lincon, “Real Time Implementation of Fuzzy Based Adaptive PI Controller for a Spherical Tank System”, *IJSSST*, Vol.14, No.6, pp. 1-8, 2013.